

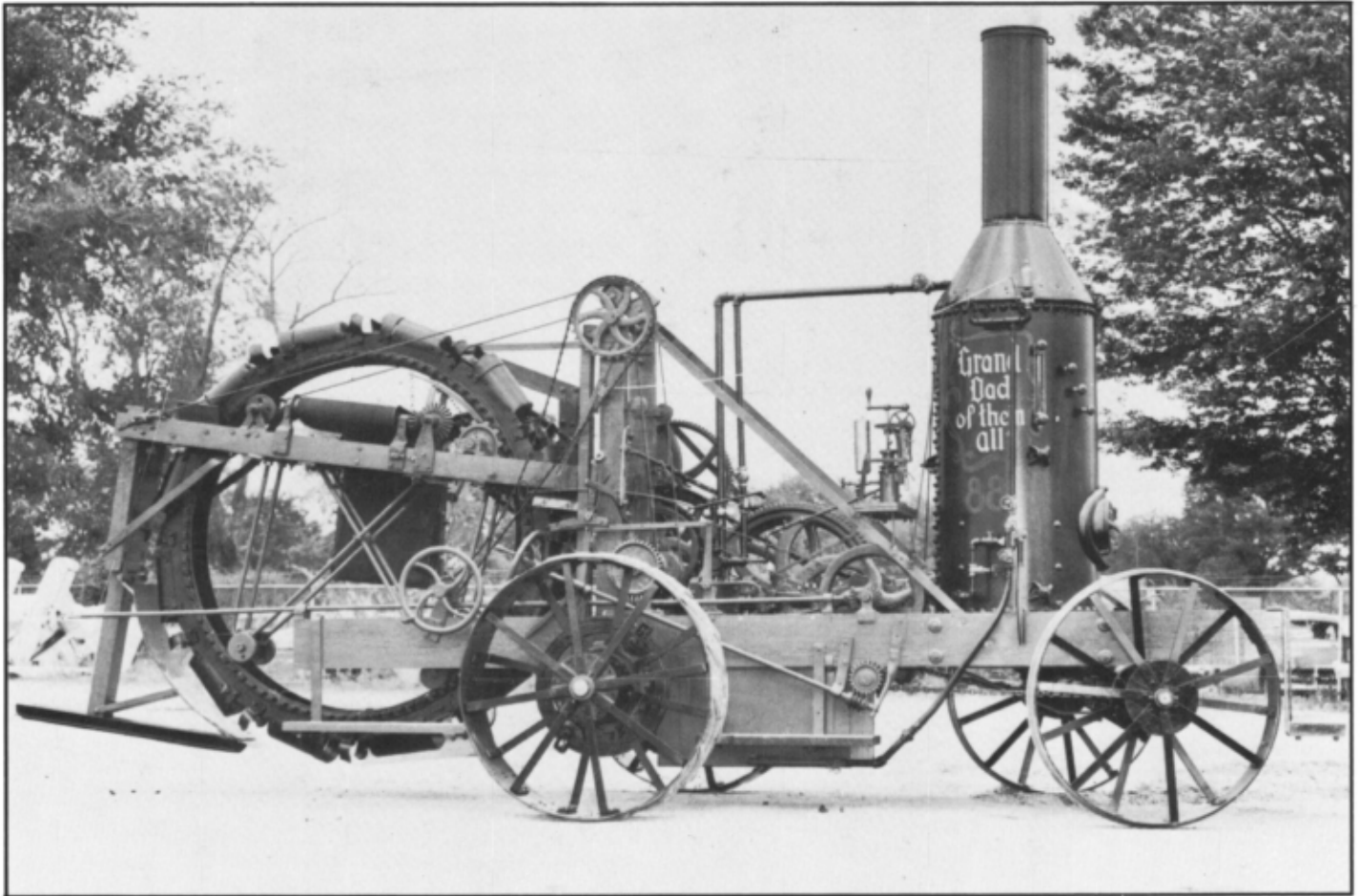

The American Society of
Mechanical Engineers

**International
Historic
Mechanical Engineering
Landmark**



**Buckeye Steam
Traction Ditcher**

Hancock Historical Museum Association

Findlay, Ohio

August 5, 1988

Historical Significance

The Old Black Swamp area of northwest Ohio and southeast Michigan developed rapidly as an agricultural community during the post-Civil War era. The forests had been cleared, but waterlogged clay soils made cultivating the land difficult. Several efforts to increase productivity, such as crop rotation, were made by farmers. Among them was underdrainage ditching, a method for laying tiles that act as conduits beneath the soil. Ditches had to be dug along gradients that followed the fall of the land. The tile piping was then laid along the bottom and covered over.

Tiling techniques for draining land were brought to the United States from Scotland in 1821 by John Johnston, who settled in Geneva, New York. Hand labor was used to dig the trenches along a gradient and to lay tile pipe sections to carry off water. Wood planks were used in lieu of tiling until the brick and tile mills could be built to produce clay tiles. A Geneva pottery maker, B. F. Whartenby, perfected and patented the first U.S. tile-making machine for Johnston.

As farmers moved westward, these techniques were studied by state commissions and farmers. Black Swamp farmers had begun digging or widening surface ditches along natural channels beginning about 1860. According to the census, Ohio had 25,000 miles of open drainage ditches by 1920. Of those, 15,000 were located in the Lake Erie drainage basin of northwest Ohio.

Mechanical ditchers enabled any farmer regardless of skill, to dig the ditches. Two workers could dig a trench at the full depth and gradient in less time than a team of fifteen skilled laborers by hand. In 1905 a mechanical ditcher raced a crew of fifty workers, digging 400 feet to the 300 feet dug by the hand ditchers. Thousands of miles of underdrainage tiles were laid between 1890 and 1920, in the Black Swamp area alone.

Buckeye Steam Ditcher

The steam-driven traction ditcher, invented by James B. Hill in the late 1880s, was the forerunner for traction ditchers used worldwide including the Florida Everglades, New Orleans, Ontario (Canada), and Africa. Hill founded the Buckeye Steam Ditcher Company in the 1890s, initially working from a Bowling Green, Ohio, machine shop. The company moved to Dresher then Carey, before being sold to the Van Buren, Heck, and Marvin Company in 1902. The company became known as the Buckeye Traction Ditcher Company when it moved to Findlay, shortly thereafter. It was the largest tile ditching and construction trenching company for about fifty years. Later models were larger and by 1908 had gasoline engines. By 1920 they were diesel-fueled. Production waned in the 1940s.

Approximately 700 Buckeye steam traction ditchers were built and shipped from Findlay before 1910.



Ultimately more than 2,000 were sold in northwestern Ohio and southern Ontario, according to the *Northwest Ohio Quarterly* (1983).

Buckeye normally would send an engineer with a new ditcher to start it up and to train operators. Wendell J. Simon was one of those engineers and was sent to Africa in 1906 on such a mission. His nephew William, who worked with the ditcher from the age of twelve until his retirement, was interviewed in 1987 during efforts to document the history of the steam ditcher.

The Buckeye Traction Ditcher Company has passed through several hands including Gar Wood and Sargent Industries. A modified version of the ditcher is still manufactured by the Ohio Locomotive Crane Company in Bucyrus, Ohio.

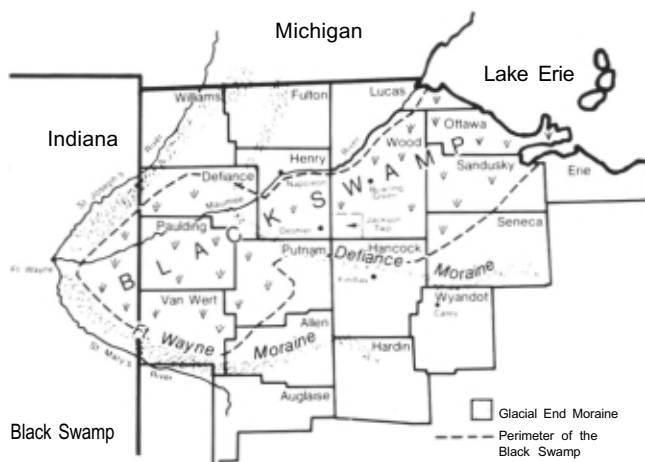

Black Swamp area. From *Northwest Ohio Quarterly*.

Operation of the Buckeye Steam Ditcher

The Buckeye steam traction ditcher was designed to dig ditches for agricultural drainage tile, but could dig open trenches for any type of pipeline or for developing open drainage ditches.

Skilled surveyors and engineers laid out the ditch direction, desired depth, and the grade of the ditch. When the Buckeye ditcher was properly steamed and aligned, the digging wheel was engaged to rotate. The machine moved forward, and the digging wheel was gradually lowered to dig its way down to the desired depth. At this point, a following support shoe was set and locked in place behind the digging wheel, and the cables supporting the back end of the wheel frame were slackened.

The dirt scooped by the digging buckets was carried toward the top of the digging wheel, dumped out of the bucket onto a cross belt-conveyor, and

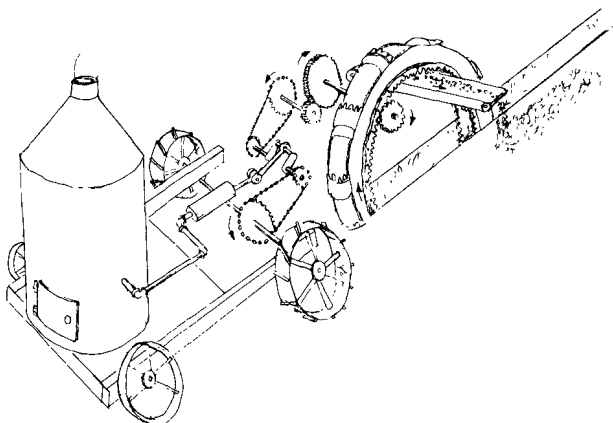
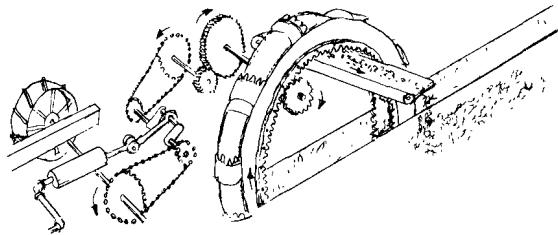

Buckeye ditcher schematic by A. B. Havens.

carried away from the digging wheel to be piled along one side of the trench.

The proper grade was maintained by sighting over previously set height targets and adjusting the height of the pivot support at the front of the digging wheel.

The digging wheel had neither spokes nor axle, which allowed it to dig to a depth equal to its diameter less the depth of the cross belt-conveyor. The width of the ditch could be altered by changing the digging buckets and adjusting the digging-wheel frame and bearings.

Early magazine articles indicate that the ditcher cut the full depth of the trench at one stroke and that 2 to 3 lineal feet a minute could be cut in ordinary soil at depth of three feet (or 1,800 feet in a working day). The ditchers were reported to dig any depth up to 12 feet, working in both swampland and hardpan conditions.

No drawings or specifications for the original ditching machine, other than the patent drawings, have been found. The machine was made without the aid of finished drawings, according to reports. Hill either made a sketch or carved a wooden pattern of the required piece, which he then took to the foundry for castings. The part was then machined to suit.

History of No. 88

No. 88, built in 1902, survived with most of its original parts, except those with heavy wear such as gears, sprockets, belts, and the boiler. The steam boiler is 5-feet tall and 3 feet in diameter. The steam engine has a 5.5-inch diameter piston with a 7-inch stroke. The drive wheel is 4 feet in diameter and the ditching wheel is 7.5 feet in diameter.

In 1936 the Buckeye Steam Ditcher Company started to look for an old ditcher to use as an advertising feature, according to a 1983 interview with Bill Wittenmeyer, a Buckeye employee, by the *Northwest Ohio Quarterly*. A unit was found in Oklahoma, returned to the company, and refurbished. After being featured in county fairs and parades, the ditcher was displayed in front of the company plant. Later this ditcher was again refurbished and donated to the Hancock Historical Museum.

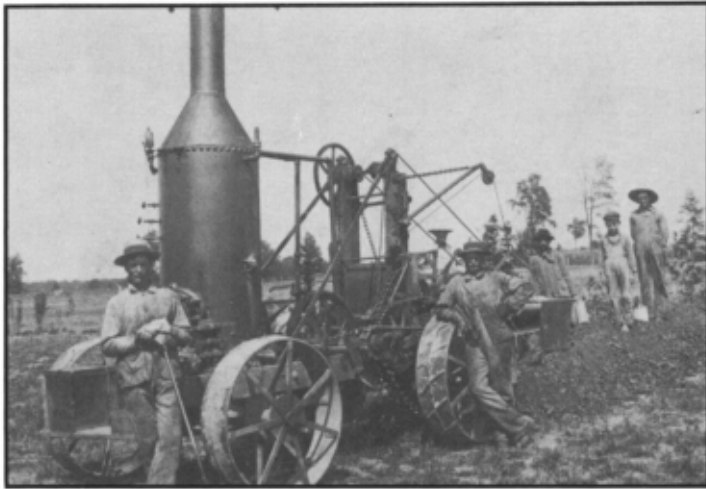

Sonnenberg family, south of Hamler, Ohio, 1905.

**INTERNATIONAL HISTORIC
MECHANICAL ENGINEERING
LANDMARK
BUCKEYE STEAM TRACTION
DITCHER
FINDLAY, OHIO 1902**

Patented by James B. Hill in 1894 as the traction ditching machine, this steam-driven ditcher (No. 88) survives as an example of the first successful mechanical ditcher. Accurately graded ditches were needed for open drainage, pipeline trenches, or placement of underground agricultural drainage tile. These machines replaced slow and costly hand labor. Steam engines were replaced early in the twentieth century by internal combustion engines.



The American Society of Mechanical Engineers

1988

**James
Hill
1856–1945**



James B. Hill was born November 29, 1856, in Fremont, Ohio, about thirty miles south-east of Toledo. From his work on a farm, he recognized the need for a practical way to place underground drain tile in the field. In 1893, while working at a machine shop in Bowling Green, Ohio, Hill built the first successful steam-driven tractor ditcher. Patent No. 523,790 for the ditcher was issued July 31, 1894.

Hill and his family moved for brief stays in Deshler and Carey, following financial difficulties during a nationwide economic depression in the 1890s. In 1902 they moved to Findlay, where the ditchers were produced by Van Buren, Heck, and Marvin Company, a machine works whose name was changed in 1906 to the Buckeye Traction Ditcher Company. Hill continued his development work on the traction drive system, and in 1907 he received Patent No. 866,647 for a traction apron that is known today as the caterpillar tread.

In 1908 Hill moved to Raceland, Louisiana, where as a farmer he developed seed corn, known as Hill's White Cob and Yellow Dent, which was sold in many parts of the United States and South America. He also continued developmental work on components of the modern tank and on equipment used in draining swamplands in Louisiana. He died in Raceland September 25, 1945, and is buried in Maple Grove Cemetery in Findlay, Ohio.

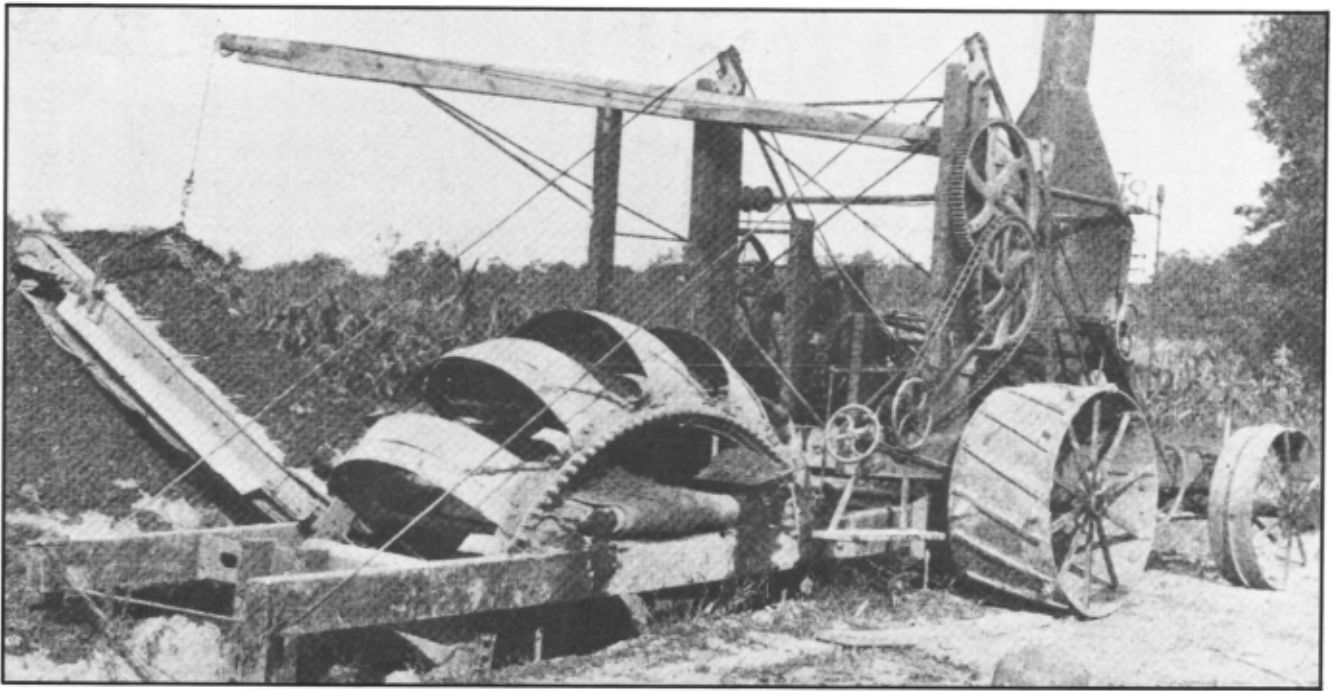

Buckeye steam traction ditcher, from *Scientific American*, September 10, 1904, page 177.

Acknowledgments

The Northwest Ohio Section of ASME gratefully acknowledges the many hours spent by those assisting with the Buckeye Steam Traction Ditcher landmark designation, specifically the Werk-Brou Company of Findlay, Ohio, for refurbishing the Buckeye Steam Traction Ditcher now on display at the Hancock Historical Museum in Findlay. Special thanks to the Northwest Ohio Antique Machinery Association for cosponsoring the designation ceremony, to Don E. Smith for all his listings of historical notes from the Findlay newspaper, to Smith Tractor Parts and Services for transporting the ditcher to the fairgrounds, and to the Maumee Valley Historical Society, the *Northwest Ohio Quarterly*, and the Jerome Library Archival Collections at Bowling Green State University, Bowling Green, Ohio.

The American Society of Mechanical Engineers

Mr. Ernest L. Daman, P.E.	ASME President
Dr. David L. Harrington	Vice President of Region V
Mr. John Alico	Chairman History and Heritage, Region V
Dr. David L. Belden, P.E.	Executive Director
Mr. Arthur W. Ebeling	Regional Director, Midwest Office

ASME Northwest Ohio Section

Mr. Gerry Ames, P.E.	Chairman
Mr. Stan Baer	Secretary
Mr. Jack Anderson, P.E.	Treasurer
Mr. C. V. Anderson	Chairman, History and Heritage

ASME National History and Heritage Committee

Prof. Euan F. C. Somerscales	Chairman
Mr. Robert M. Vogel	Secretary
(Curator Emeritus, Smithsonian Institution)	
Dr. Robert B. Gaither	
Dr. Richard S. Hartenberg, P.E.	
Dr. J. Paul Hartman, P.E.	
Mr. Joseph P. Van Overveen, P.E.	
Dr. R. Carson Dalzell	Chairman Emeritus
Ms. Carron Garvin-Donohue	Staff Liaison

History and Heritage Program of the ASME

The ASME History and Heritage Program began in September 1971. To implement and achieve its goals, ASME formed a History and Heritage Committee, composed of mechanical engineers, historians of technology, and the Curator of Mechanical and Civil Engineering at the Smithsonian Institution. The Committee provides a public service by examining, noting, recording, and acknowledging mechanical engineering achievements of particular significance. For further information, contact Public Information, the American Society of Mechanical Engineers, 345 East 47th Street, New York, NY 10017, 212-705-7740.

Designation

The Buckeye steam traction ditcher is the 25th international landmark to be designated. Since the ASME Historic Mechanical Engineering Program began in 1971, 90 national and 11 regional landmarks and 5 sites and 1 collection have been recognized. Each reflects its influence on society, either in its immediate locale, nationwide, or throughout the world.

An ASME landmark represents a progressive step in the evolution of mechanical engineering. Site designations note an event or development of clear historical importance to mechanical engineers. Collections mark the contributions of a number of objects with special significance to the historical development of mechanical engineering.

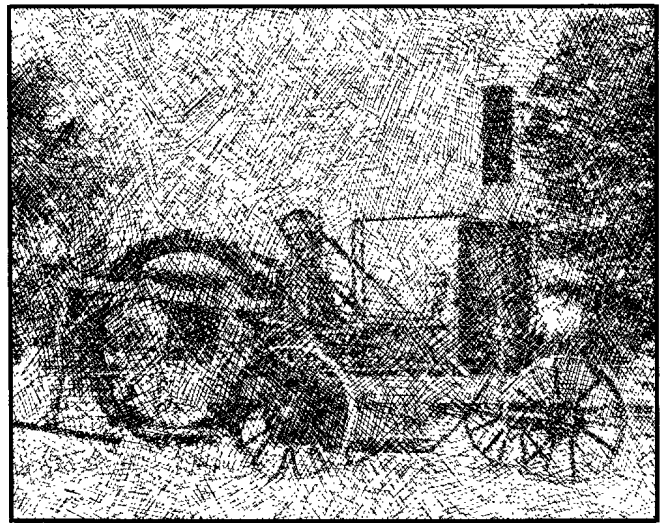

The ASME Historic Mechanical Engineering Landmarks Program illuminates our technological heritage and serves to encourage the preservation of the physical remains of historically important works. It provides an annotated roster for engineers, students, educators, historians, and travelers. It helps establish persistent reminders of where we have been and where we are going along the divergent paths of discovery.

Further Reading

Wilhelm, Peter W., "Draining the Black Swamp: Henry and Wood Counties, Ohio, 1870-1920," *Northwest Ohio Quarterly*, Vol. 56, No. 3: 79-95, Maumee: Maumee Valley Historical Society, Summer 1984.

Perkins, Frank C., "The Buckeye Traction Ditcher," *Scientific American*, New York: Munn and Company, September 10, 1904.

History of the Hancock Historical Museum Association

In 1970 a group of Findlay business people organized the Hancock Historical Museum Association to establish a local collective of significant historical items for public display. In June of that year the group acquired the Hull House, 422 West Sandusky Street, a former residence built in 1880.

A membership drive gained widespread support. Officers were E. L. Heminger, President; Jack Harrington, Vice President; Harold Corbin, Treasurer; R. Joseph Opperman, Secretary. Other charter board members were James Brucklacher and David Hollington. The first part-time curator was Betty Dunlap, who retired in 1985. Christopher Haley is currently curator-director.

The museum was opened to the public October 30, 1971. By 1974 the Kimmel House was purchased, but has been recently resold. A log house, donated to the Association, was rebuilt on the property. A one-room schoolhouse, which was donated recently, is located 3 miles east of Findlay. A building drive in 1984 resulted in the completion of a building addition to the museum in 1987. The opening of the exhibit center was October 30, 1987.

The Hancock Historical Museum Association is a nonprofit organization that operates through individual and corporate donations and is not tax supported.