

J. B. HILL.
 ROLLER BEARING APRON WHEEL.
 APPLICATION FILED MAY 29, 1913.

1,128,138.

Patented Feb. 9, 1915.

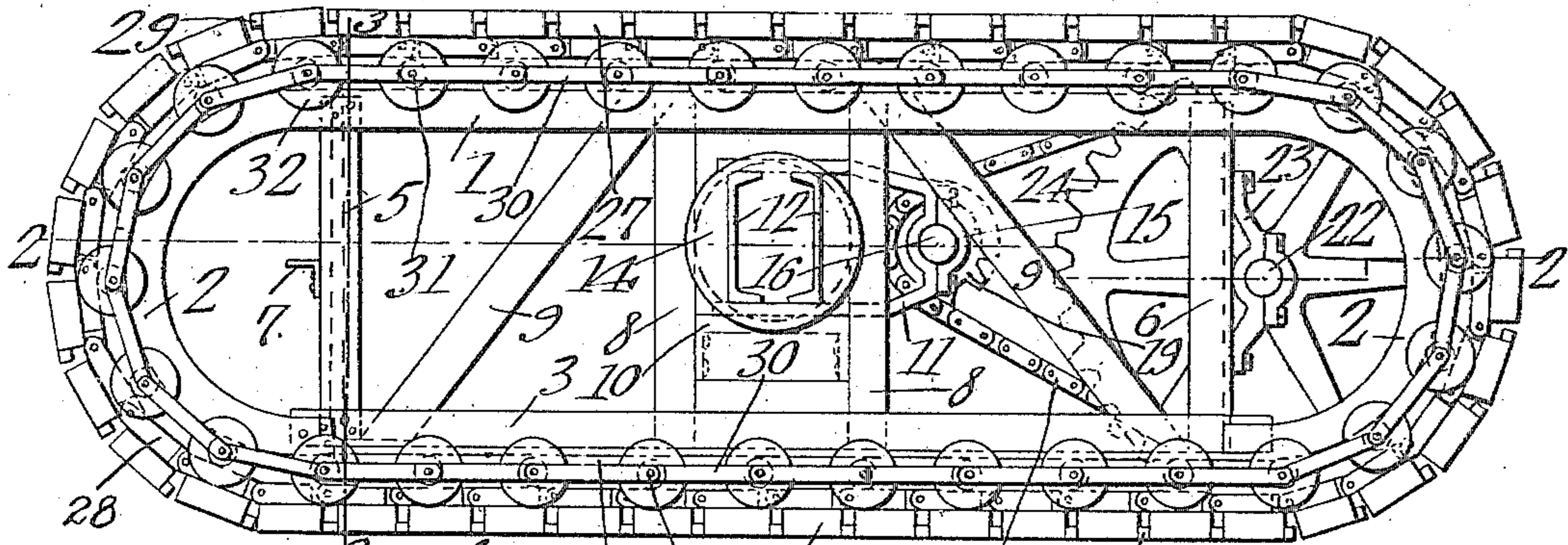

Fig. 1.

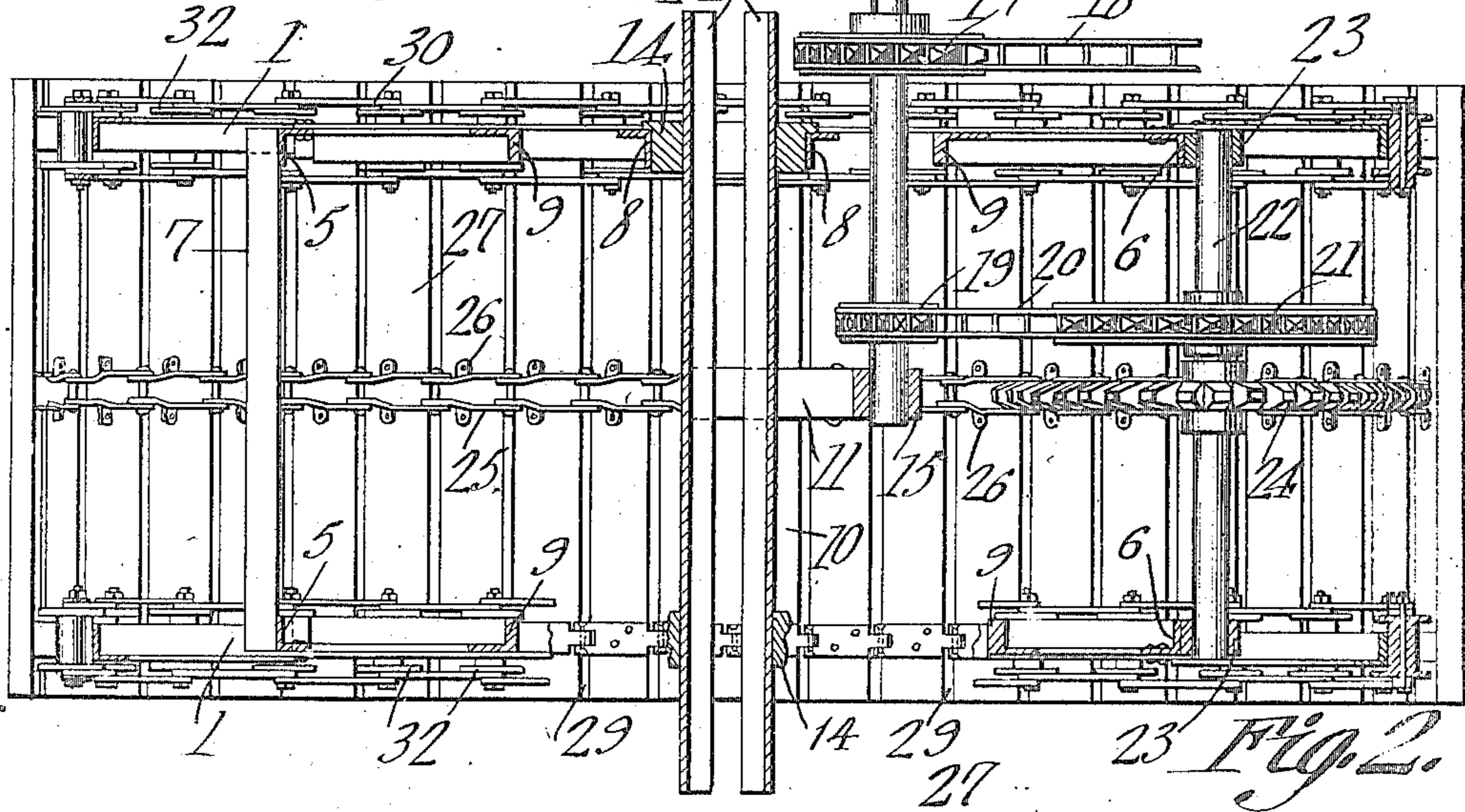

Fig. 2.

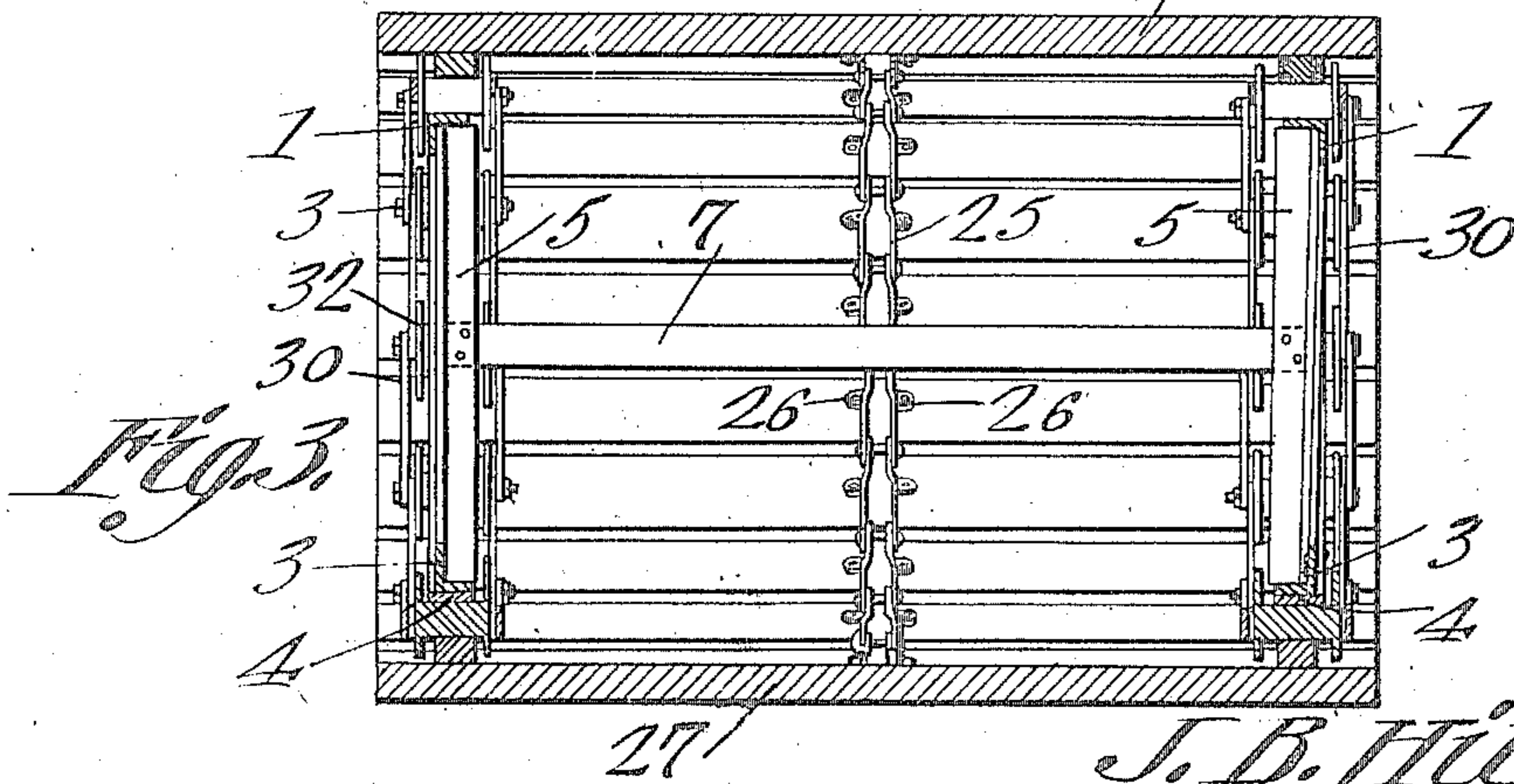

Fig. 3.

Witnesses

J. P. Gomez
S. Willard

J. B. Hill,

Inventor

by

Chas. H. Coe

Attorneys

UNITED STATES PATENT OFFICE.

JAMES B. HILL, OF RACELAND, LOUISIANA.

ROLLER-BEARING APRON-WHEEL.

1,128,138.

Specification of Letters Patent.

Patented Feb. 9, 1915.

Application filed May 29, 1913. Serial No. 770,729.

To all whom it may concern:

Be it known that I, JAMES B. HILL, a citizen of the United States, residing at Raceland, in the parish of Lafourche and State of Louisiana, have invented a new and useful Roller-Bearing Apron-Wheel, of which the following is a specification.

The device forming the subject matter of this application is adapted to be assembled with a traction engine or like structure which embodies a movable apron or "caterpillar" of endless construction, and adapted to engage the ground.

One object of the present invention is to provide novel means for supporting and actuating the endless ground engaging member.

Another object of the invention is to provide novel means whereby the supporting frame may be permitted to have the necessary vertical movement without interfering with the actuation of the endless ground engaging member.

It is within the scope of the invention to improve generally and to enhance the utility of devices of that type to which the present invention appertains.

With the above and other objects in view, which will appear as the description proceeds, the invention resides in the combination and arrangement of parts and in the details of construction hereinafter described and claimed, it being understood that changes in the precise embodiment of the invention herein disclosed can be made within the scope of what is claimed without departing from the spirit of the invention.

In the drawing: Figure 1 shows the invention in side elevation; Fig. 2 is a section on the line 2—2 of Fig. 1, parts being removed; and Fig. 3 is a section on the line 3—3 of Fig. 1.

In carrying out the invention there is provided a frame about which an endless ground engaging member travels. The frame is a composite structure and comprises primary or top bars 1 which may be angle members, the primary bars 1 terminating in curved ends 2. A bar in the form of an inverted closed-ended channel 10 is terminally attached to the posts 8 and extends across the frame. Secondary or bottom bars 3 are provided, the bars 3 preferably being angle members. The ends of the bottom bars 3 are supported upon the upper faces of the horizontal flanges of the curved

ends 2. A wear strip 4 is applied to the lower face of the horizontal flange of the bottom bar 3 and extends between the extremities of the curved ends 2, so that a flush surface is provided, the said flush surface comprising the outer faces of the curved ends and the under face of the wear strip 4.

The bars 1 and 3 and the curved ends 2 are connected by end posts 5 and 6. The posts 5 may be connected by a transverse tie bar 7 which may be an angle member. The top bars 1 may be connected with the bottom bars 3 by means of intermediate posts 8, constituting bearings, as will be described hereinafter. The intermediate posts 8 preferably are angle members. Extending diagonally of the rectangles defined by the posts 5 and 8 and 6 and 8 are counters 9 which may be angle members.

A support is mounted for relative vertical movement between the intermediate posts or bearings 8. The support comprises a pair of channel members 12 to which is secured a yoke 11. Secured to the channels 12 are circular flanged disks 14, mounted to rock between the intermediate posts or bearings 8 and upheld by the bar 10. This construction permits the channel members 12 to rock on the frame. Secured to the yoke 11 is a bearing 15.

The driving mechanism includes a shaft 16 which is journaled for rotation in the bearing 15 and is supported, additionally, if desired, in any suitable manner. The shaft 16 may be provided at its outer end with a sprocket wheel 17, about which is trained a sprocket chain 18, leading to the motor of the traction structure; although, obviously, the shaft 16 may be driven in any suitable manner. Mounted upon and secured to the shaft 16 and located adjacent the longitudinal center of the frame is a sprocket wheel 19 about which is trained a sprocket chain 20, the sprocket chain 20 being trained about a sprocket wheel 21 secured to a transverse shaft 22, journaled for rotation in bearing brackets 23 carried by the posts 6. Secured to the shaft 22 is a sprocket wheel 24 around which is trained a sprocket chain 25 preferably located along the longitudinal center of the main frame.

An endless ground member is provided, the same comprising a plurality of slats secured to pivotally connected links constituting a chain 28. The links of the sprocket

chain 25 may be equipped with laterally extended feet 26 which are secured to the slats 27 on the chain 28. The slats 27 on the chain 28 are equipped adjacent their outer surfaces with lugs 29. These lugs 29 constitute means for preventing an undue sagging of the ground engaging member.

Interposed between the ground engaging member and the frame proper is an anti-frictional support for the ground engaging member, the same comprising a chain 30, the links of which are connected by pivot elements 31 constituting bearings for flanged rollers 32. The rollers 32 receive the links of the chain 28 and are adapted to traverse around the tracks defined by the top bars 1, the curved ends 2 and the wear strip 4 which is supported by the bottom bar 3.

In practical operation, rotary movement is imparted to the shaft 16 from the motor by suitable mechanism, such as the sprocket chain 18 and the sprocket wheel 17. When the shaft 16 is driven, movement will be imparted to the sprocket chain 20 and from the sprocket chain 20 through the sprocket wheel 21 to the frame supported shaft 22. The shaft 22 through the medium of the sprocket wheel 24 will impart movement to the sprocket chain 25, and since this chain 25 is secured to the constituent slats 27 of the ground engaging member, movement will be imparted to the ground engaging member, so that the ground engaging member will move around the periphery of the frame 1-2-4. Obviously, the chain 30 and the rollers 32, being interposed between the frame and the ground engaging mem-

ber, will serve to support the ground engaging member anti-frictionally, the chain 30 and the ground engaging member having independent relative movement around the periphery of the frame.

It is to be noted that the support, comprising the members 12 and 11, and associated parts, is mounted to rock between the bearings or posts 8 of the frame 1-2-4 and on the bar 10, and consequently, the necessary movement is permitted in the supporting frame.

Having thus described the invention, what is claimed is:—

In a traction attachment of the class described, a frame comprising top and bottom bars; posts connecting the top and bottom bars; a support comprising circular disks mounted to rock between the posts and supported by the frame; a yoke projecting from the support; a shaft journaled in the yoke; a sprocket wheel carried by the shaft; a shaft journaled on the frame; a sprocket wheel carried by the last specified shaft; a sprocket chain trained around the sprocket wheels; an endless ground-engaging member mounted to move around the frame; and means for operatively connecting the ground engaging member with the frame-supported shaft.

In testimony that I claim the foregoing as my own, I have hereto affixed my signature in the presence of two witnesses.

JAMES B. HILL.

Witnesses:

L. M. FOLSE,
FRANKLIN P. GUIDROZ.